

NATIONAL BUSINESS AND TECHNICAL EXAMINATIONS BOARD (NABTEB)

ELECTRICAL INSTALLATION AND MAINTENANCE WORKS (041)

MAY/JUNE, 2008

Question 1:

(a) Sketch the British standards symbols which represent the following items:

- (i) Filament lamp
- (ii) Meter
- (iii) Pull Switch.
- (iv) Bell Indicator.

(b) Explain the following terms as applied to industrial installation.

- (i) Duct.
- (ii) Trunking.

(a) State the advantages if trunking over ducting system.

Answer:

1(a) (i)

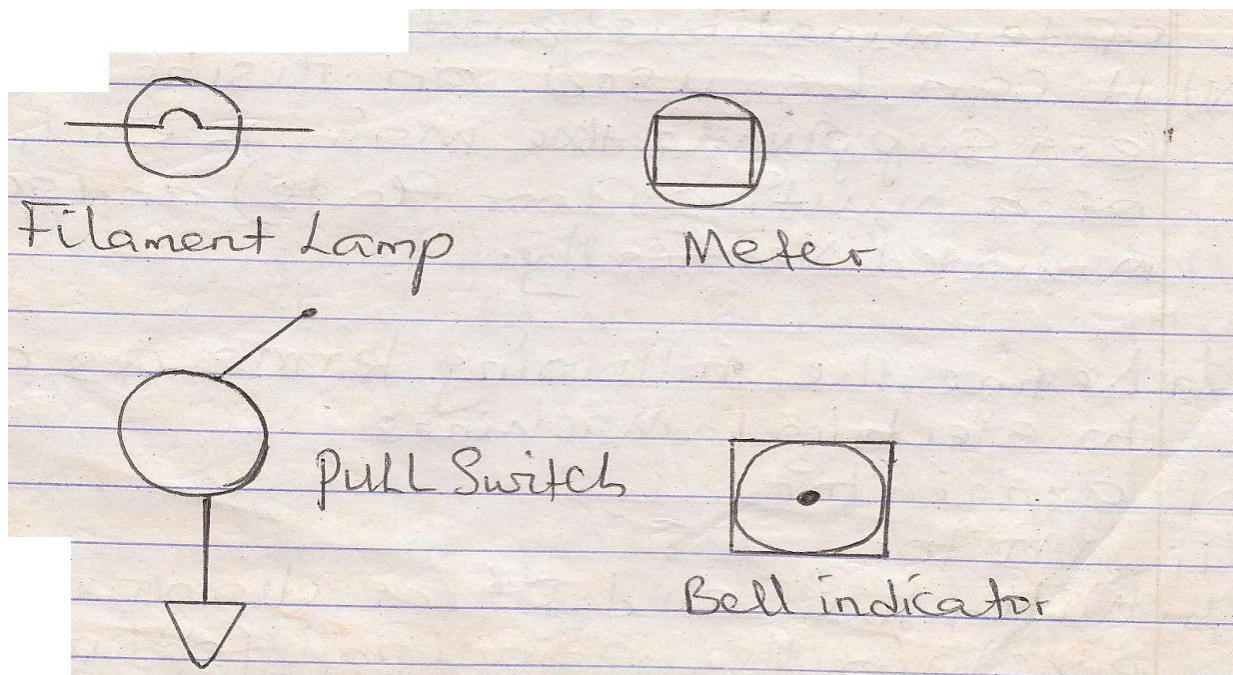

(b) (i) Duct:

A closed passage – way formed underground or in a structure and intended to receive one or more cables which may be drawn in space factor is 35%.

(b)(ii) Trunking:

A fabricated casing for cables normally of rectangular cross section of which one side is removable or hinged to allow cables to be laid there in. Spare factor is 4.5%.

(c) Advantages of trunking over ducting system are:

- (i) It serves as earth continuity conducts.
- (ii) It has segregations which accommodate extra low voltage, low voltage or medium voltage.
- (iii) It is supplied with large range of terminations and connections.
- (iv) It can be used on rising mains (e.g. supplying the main to each floor of a multi-floor flats) and generally mounted vertically.

Question 2(a): Define the following terms as applied to electrical machines.

- i. Generator
- ii. Motor

(b) With the aid of a diagram, explain the principal features of a.b.c. machine.

Answer 2(a)

- (i) Generator: Converts mechanical energy to electrical energy. It operates by the magnetic effects of current.
- (ii) Motor: Converts electrical energy to mechanical energy. It also operates on the principles of magnetic effects of current.

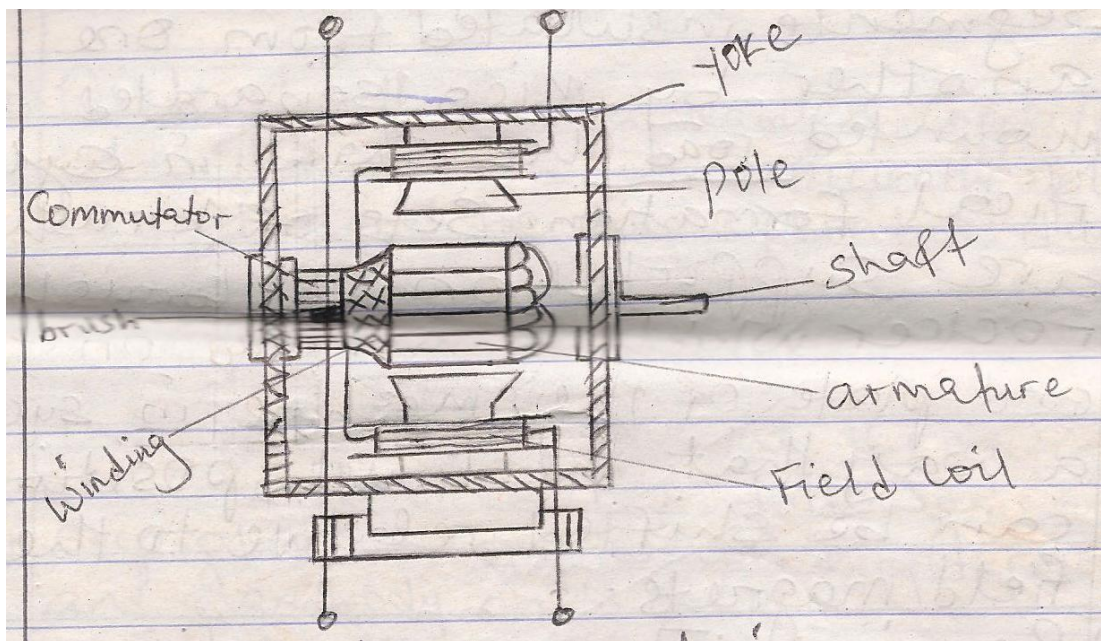

A D.C Machine

- (iii) **Field Magnetic System:** This provides a magnetic flux in the air gap or the machine. It comprises the yoke or frame generally made of mild steel from which projecting in wards are pole cores made of steel laminations terminating in poles shoes. The number pole varies with each design.
- (iv) **Armature:** Comprises of a number of conductors (the armature winding) located in slots round the periphery of laminated armature. The ends of various coils form the winding are connected together either in lap or wave form and soldered to the commutator.
- (v) **Commutator:** The commutator is made up of copper bars or segments insulated from one another by mica separated and mounted round, The shaft in cylindrical formation. Sets of brushes are supported on a brush rocker which is mounted on the end plate of the machine in such a way that the brush positions can be shifted relative to the field magnets.
- (vi) **Bearings:** The commonest type is the ball bearing. Its advantages are that it occupies little space longitudinally and requires little maintenance.

Question:

3(a) Explain briefly the following component parts of MICC Cable.

- (i) Conductors.
- (ii) Insulators.
- (iii) Outersheath.

3(b) State the procedure for the termination of MICC Cable.

Answer:

- 3(a) (i) Conductors: Each core consists of a single copper/aluminum metal and allows the passage of electricity.
- (ii) Insulator: The insulation between the cores is magnesium oxide a material capable of withstanding high temperature but absorbent to moisture.
- (iii) Outersheath: Is a seamless copper/aluminium tube. The sheath is sufficiently pliable to withstand bending operations during cable installations. It serves as earth continuity conductor.
- (a) The procedure for the termination of MICC cable is as follows:
- (i) Slip gladnut compression ring (termed olive) and glandbody on to cable.
 - (ii) Strip sheath using stripping tool.
 - (iii) Screw on sealing pot (forced thread).
 - (iv) Slip disc and sleeve assembly on cores.
 - (v) Press compound into sealing pot (all copper particles must be removed).
 - (vi) Test termination on completion (between poles and poles to earth).

Question 4

- (a) Explain the function of a “micrometer” in cable jointing.
- (b) State four types of electrical joints.
- (c) State the TWO main types of joint methods with examples.

Answer:

- (a) A “Micrometer” is used to measure conductor diameters/gauging the correct size of wire.
- (b) Types of electrical joints are:
- (i) Scarf Joint.
 - (ii) Bell hanger’s Joint.
 - (iii) Tee – Twist joint.
 - (iv) Through married joint.
 - (v) Britannia Joint.
 - (vi) Telephone Joint.
- (c) The two main types of joint methods are:-
- (i) Heating method e.g. soldering, welding and brazing.
 - (ii) Mechanical/pressure method e.g. clamping, bolting and riveting.

Question 5(a). Explain the functions of the following in soldering operations:

- (i) Soldering.
- (ii) Soldering bit.

(b) State FOUR materials required for soldering electrical conductors.

Answer:

(a) (i) Soldering: The process of soldering in electrical work is generally used to make joints in conductors and to terminate a conductor for a mechanical connection to an appropriate terminal in electrical equipment. This method involves the use of molten metal introduced to the two surfaces to be joined. The metal used for joining copper surface is solder which is an alloy of tin lead. The disadvantage of soldering is that the process/method makes the joint a non-separable contact.

OR A method of joining cables using solder flux and soldering iron.

(ii) Soldering bit: The function of soldering bit is to store and carry heat source to the work to store molten solder, deliver the molten solder and with draw surplus solder. The material for the bit is most often copper on which molten solder clings readily without difficulty. The heating media for a soldering bit are considered as coal gas paraffin or petrol flames and electric heating or this is the tool used during soldering, the bit should be heated until a green flame appears and must always be kept clean.

(b) The materials required for soldering electrical materials are:

- (i) Solder.
- (ii) Flux.
- (iii) Wire Brush
- (iv) Solder Collector
- (v) Stove. Burning Charcoal.
- (vi) Paraffin/Petrol Flames.
- (vii) File
- (viii) Rags

Question 6:

- (a) Describe with diagram the construction features of a co-axial cable in Data communications.
- (b) State the reason for using a co-axial cable for distribution system.
- (c) State two advantages of fiber – optic link compared with microwave links.

Answers:

(a)

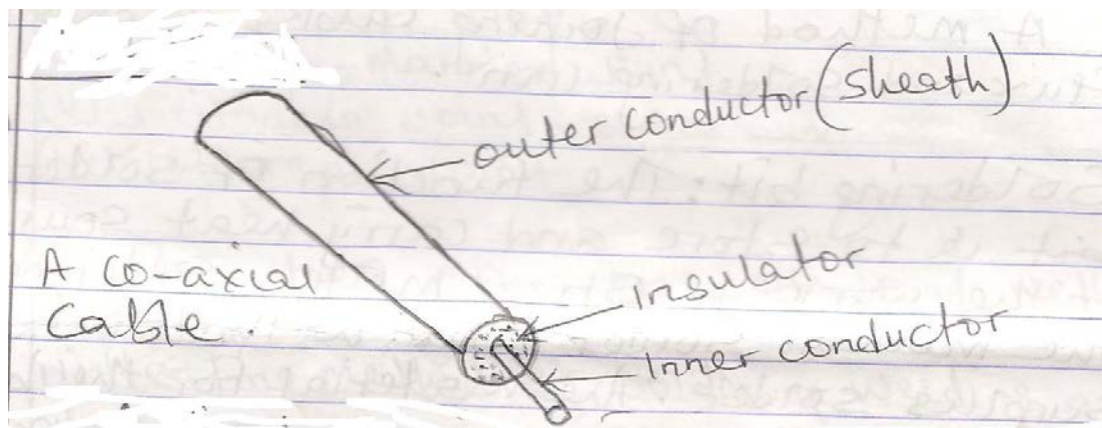

A Central wire is surrounded by a cylindrical or tabular conductor and the two conductors (inner and outer) are separated by an insulator. The co-axial cable is used for distributing CATVE signals at RF channel frequencies and has the advantages of shielding.

(b) Reasons for using a co-axial cable for distribution system are:

- (i) It is efficient.
- (ii) It has added advantages of shielding.
- (iii) Light in weight.

- (c)
- (i) Fibre –Optic cable is not as heavy as copper conductors making it convenient for installation.
 - (ii) Attenuation of light is much less er than the losses with conduction or radiation of an RF carrier wave.
 - (iii)It provides modulation that includes a tremendous range of frequencies.
 - (iv) No cross-over distortion with the Fiber-Optic link.

Question 7:

a. Explain the following maintenance terms.

- i. Predictive
- ii. Corrective
- iii. Preventive

b. Explain the procedures for overhauling a motor in electrical winding workshop

Answer:

- (a) (i) **Predictive:-** Maintenance procedure based on record keepings and reading of testings. The intelligent use of records can often lead to detection of faults before dangerous situation arises having a pre-knowledge of past break down.
- (ii) **Corrective:** Maintenance carried out as a result of major or sudden breakdown of machines. This maintenance process is always expensive and disrupts production.
- (iii) **Preventive:** This involves the maintenance engineer having knowledge of the state of each item and circuit such as circuit breakers, switches and fuse boxes. It also embraces servicing of plants such as rotating plants bearing machine noises, mechanical defects and insulation overheating. Maintenance carried out regularly to prevent breakdowns and enhance productivity.

(b) The procedure for overhauling a motor in electrical winding workshop is as follows:

- (i) Dismantle the motor carefully.
- (ii) Clean away all dust, dirt, oil and grit using a blower, bellow or compressed air hose.
- (iii) Check all parts for damage wear and repair or replace as found necessary.
- (iv) Measure the insulation resistance and dry out winding if necessary until the correct value is obtained.
- (v) Repair or replace any damage winding.
- (vi) Reassemble all parts. Ensure that machine leads are on their correct terminals and all parts are well tightened and locked.
- (vii) Check insulation resistance.
- (viii) Check air gaps.
- (ix) Commission and test.

Question 8

- (a) State the functions of FIVE tools used for winding.
- (b) Explain the effects of replacing a winding with a wrong wire guage.
- (c) State the tool with which to measure the S.W.G. of a winding conductor.

Answer (a)

- (a) i. Spanner: Used for tightening/loosening of nuts and bolts.

- (ii) Scissors: Used for cutting insulators and sleeves, wires or plyboard papers.
 - (iii) Mallet hammer: For mounting and shapping of armature coils.
 - (iv) Long-nose plier: Is used for twisting of wires and inserting of nuts/bolts.
 - (v) Handgloves: Used to protect injuries e.g. chemicals e.t.c.
- (b)
- (i) Overheating and burning of winding coils.
 - (ii) Speed would be affected
 - (iii) Inability of the machine to carry load.
 - (iv) Torque would be affected.
 - (v) Efficiency of machine is reduced.
 - (vi) Constant breakdown of machine.
- (c) The tool to measure the S.W.G. of a winding conductor is a “Micrometer” screwguage.

Question 9

- (a) Define the term “armature reaction”.
- (b) Explain the undercutting of a commutator.
- (c) State the causes of sparking on commutator.
- (d) State two possible observations for a worn-out ball bearings.

Answers:

- (a) Armature reaction is defined as the distortion of the main field due to the current flowing in the armature conductor.
- (b) Under cutting of a commutator is defined as the reduction of mica protrusion between commutator segments using a saw blade/cutting of the common insulation (mica) below the commutator bars.
- (c) The causes of sparking of commutator segments are:
 - (i) Shorted armature.
 - (ii) High Mica.
 - (iii) Worn-out Brushes.

- (iv) Dirty Commutator.
 - (v) Armature Reaction.
 - (vi) Overloading.
 - (vii) Wrong position of brushes.
 - (viii) Earthed armature coil.
- (d) The possible observations for a worn-out ball bearings are:
- (i) Broken balls.
 - (ii) Undue Noise.
 - (iii) Dry Lubricant.
 - (iv) Low Grease Content.
 - (v) Poor Clearance between ball bearings and shaft.